

()

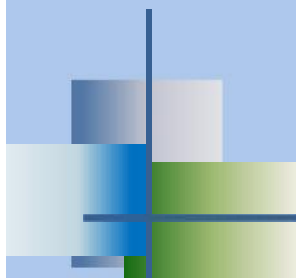



()



1889 .

,

,





C

(/)

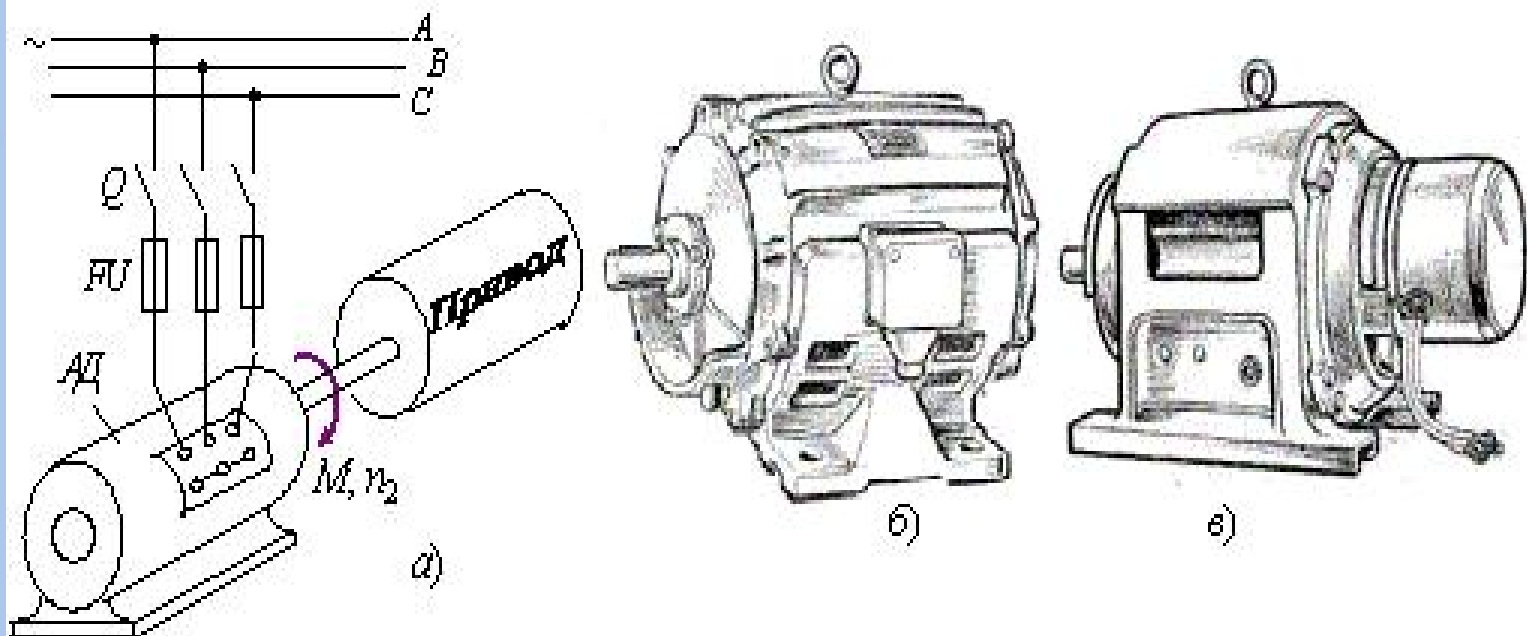

)
)

,) / ,

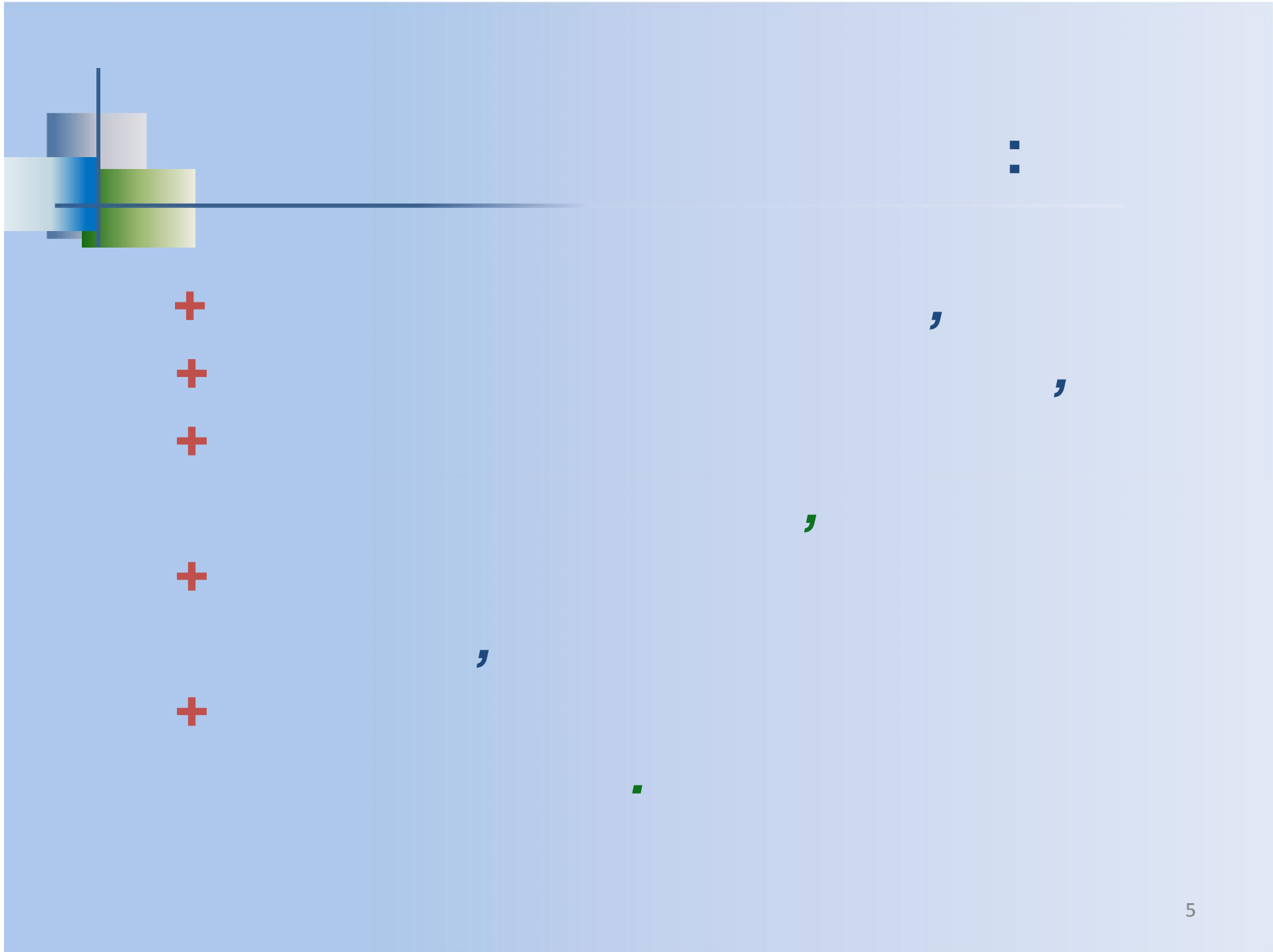

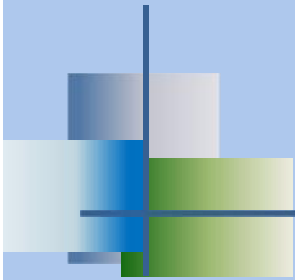

⋮

(s)

(

s = 0,2...0,3);

;

.

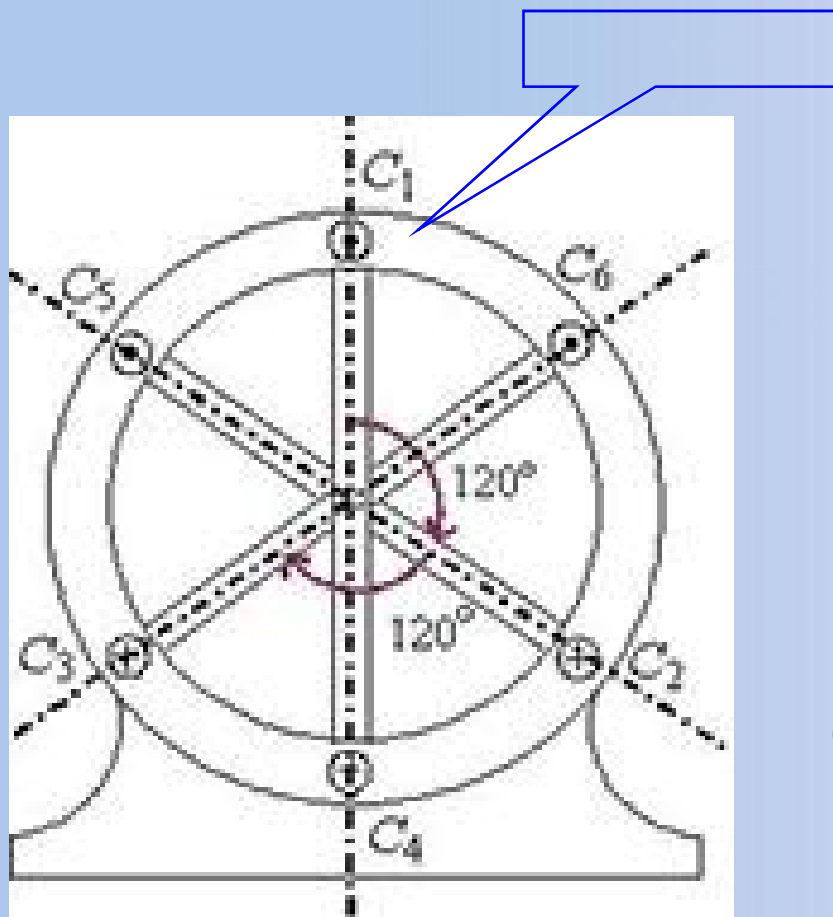
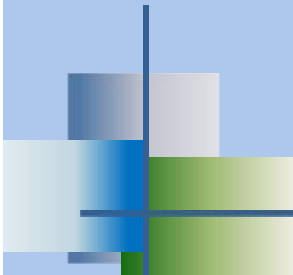

(0,3...0,5).

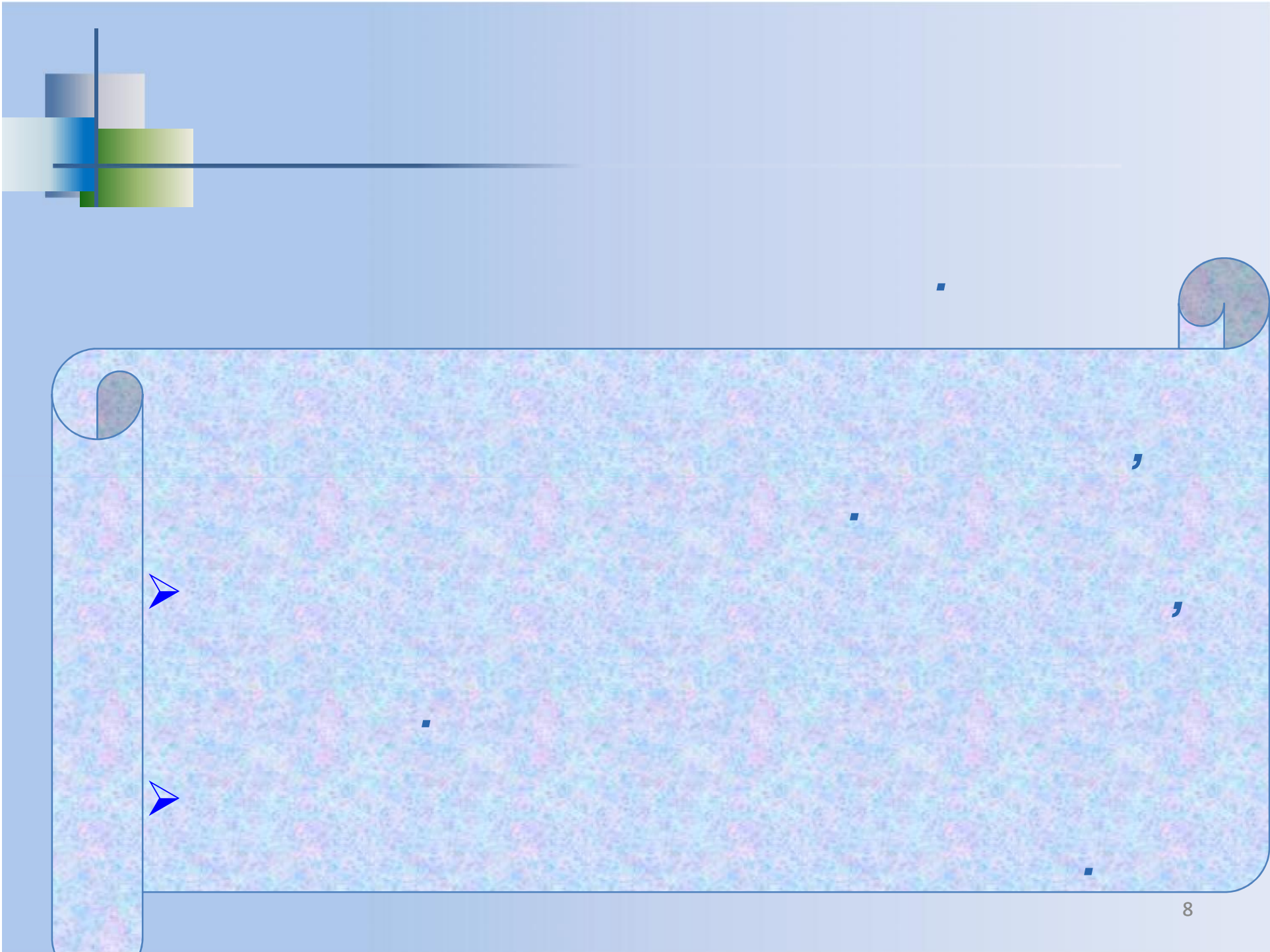

120°

((); 2 - 5 () 3 - 6
(().

380

220)

(

,

,

.

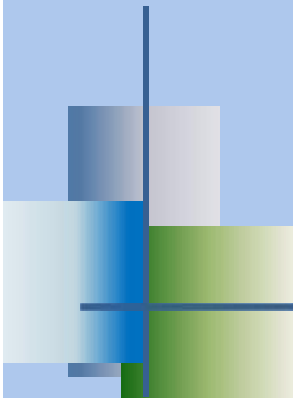

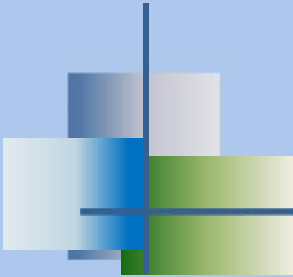

3~380 В, 50 Гц

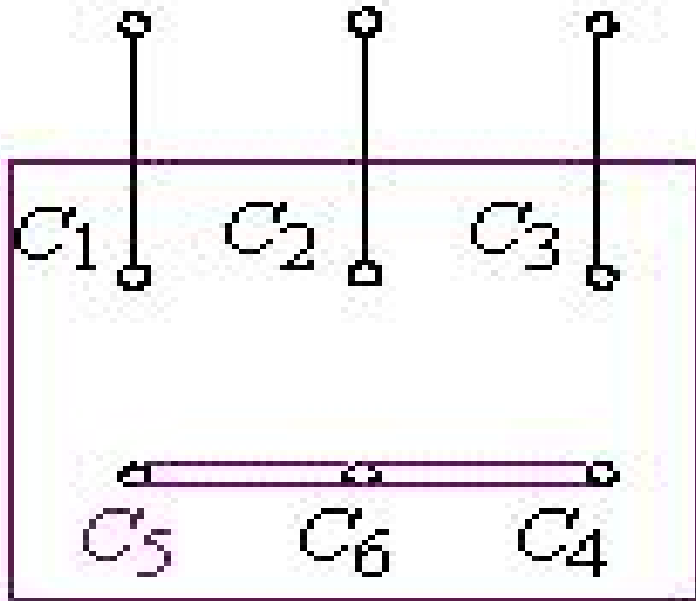

)

3~380 В, 50 Гц

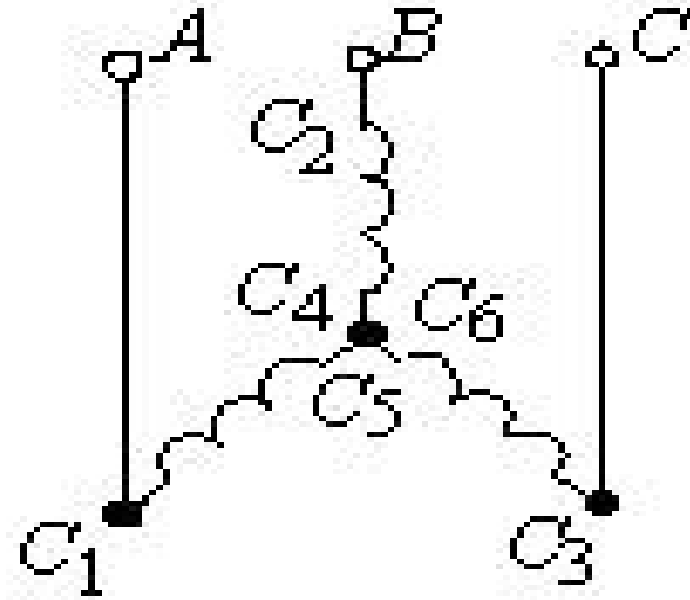

)

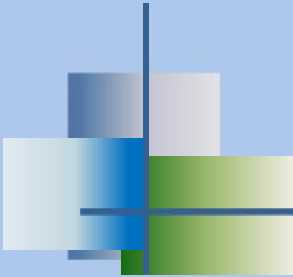

3~220 В, 50 Гц

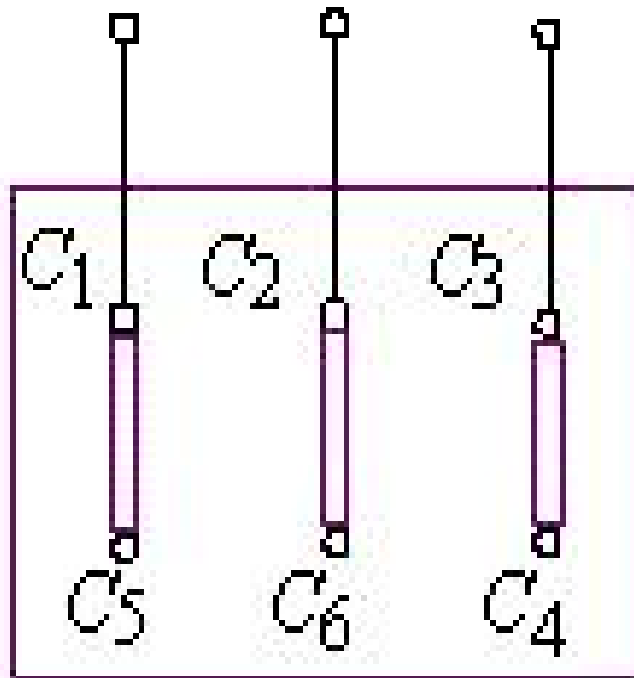

)

3~220 В, 50 Гц

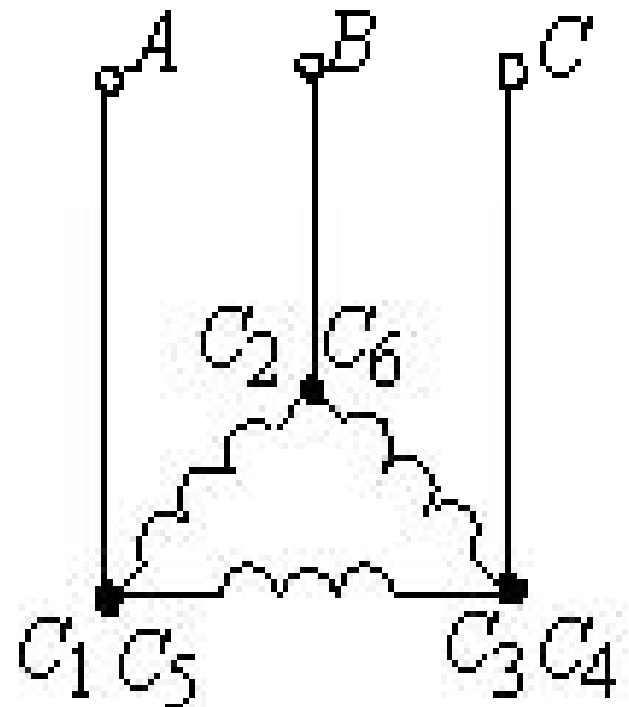

)

Виды соединений обмоток трехфазных электродвигателей

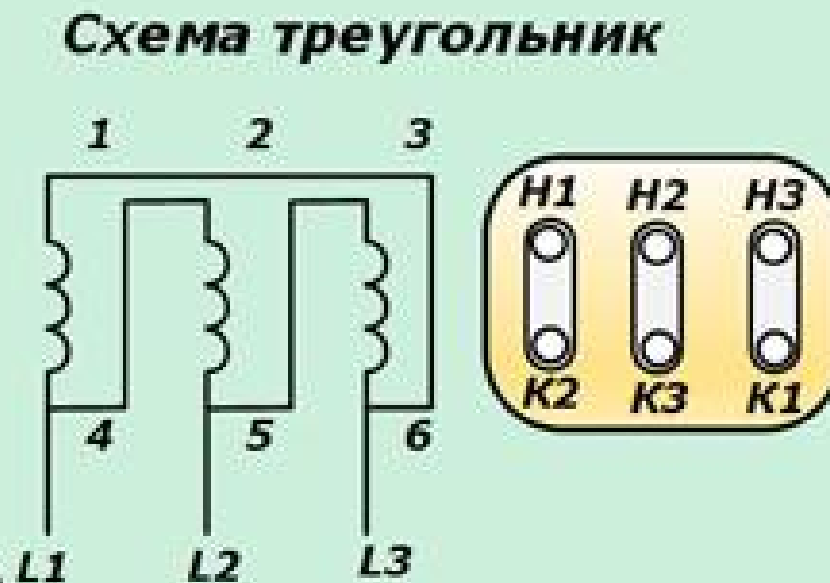
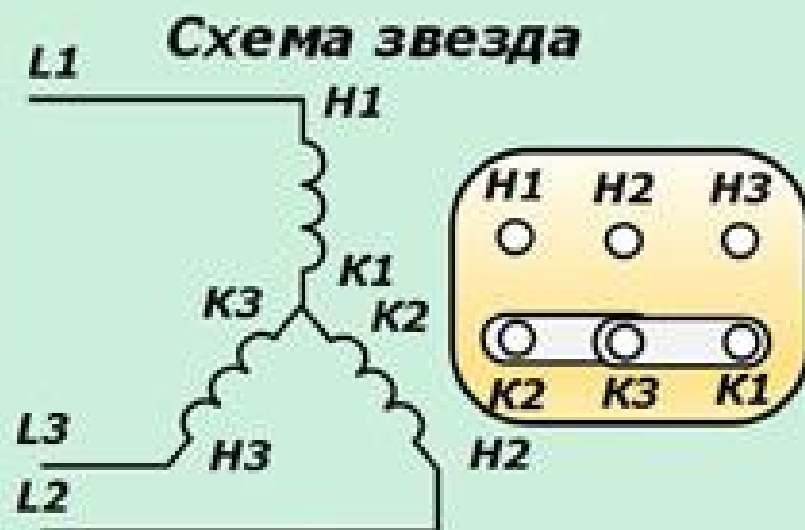

<http://elektrik.info/>

()

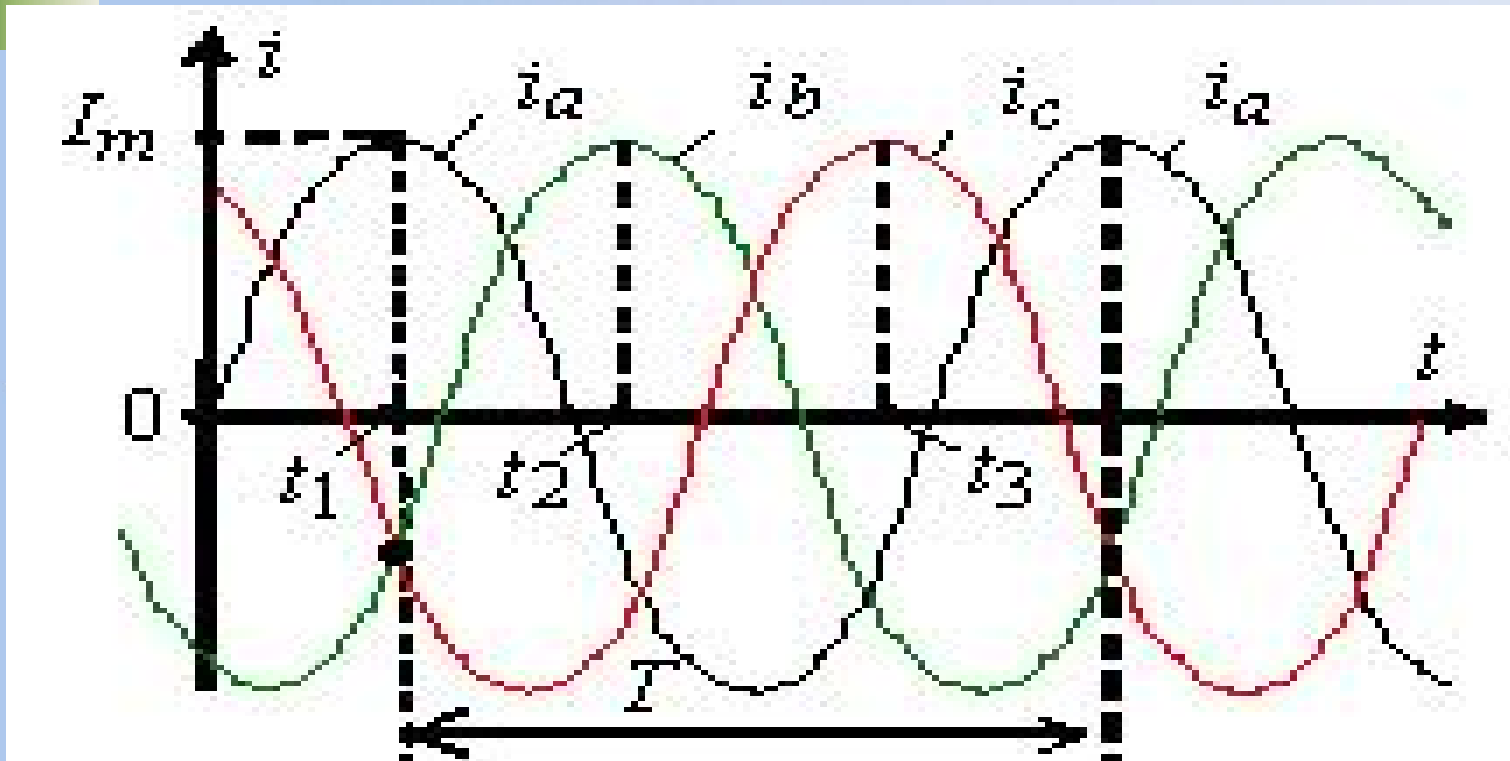

$i_a, i_b, i_c.$

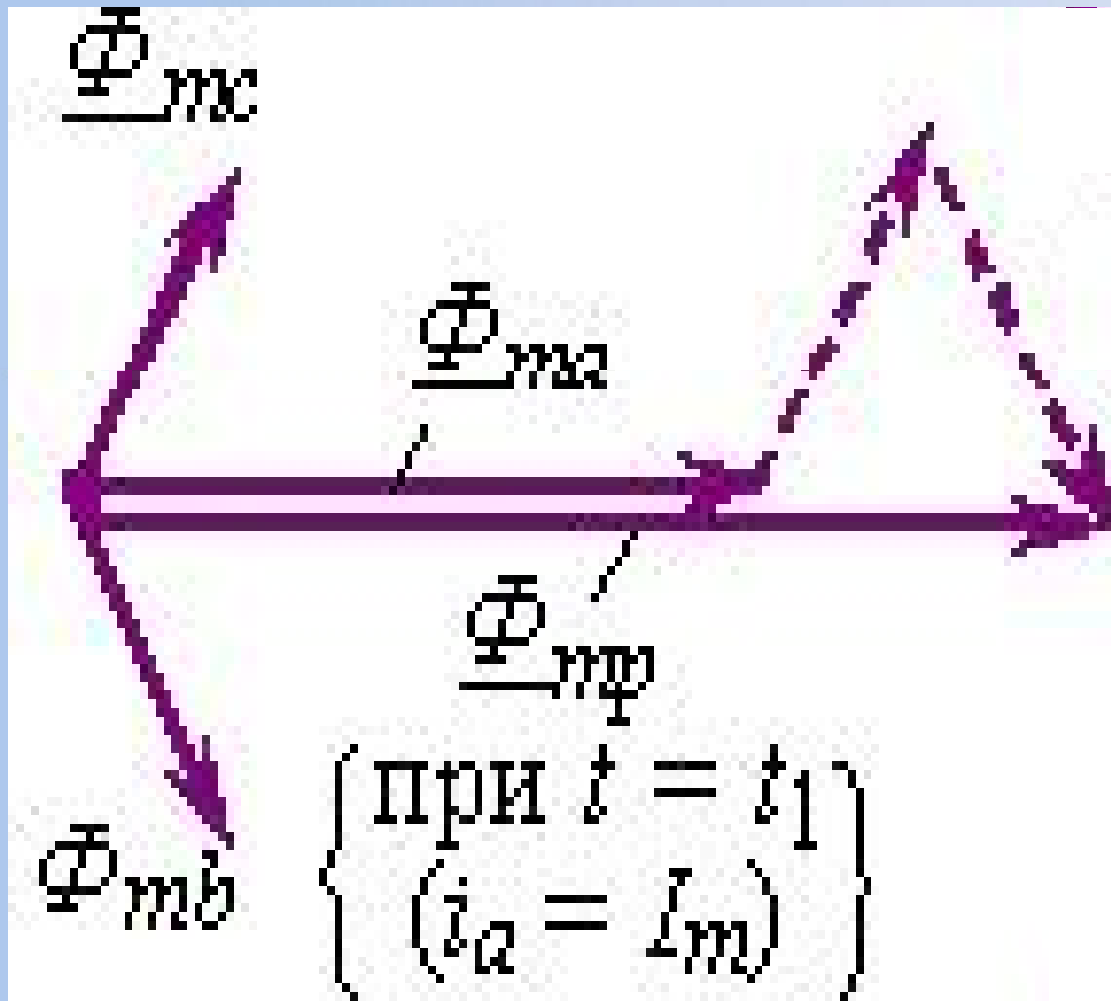

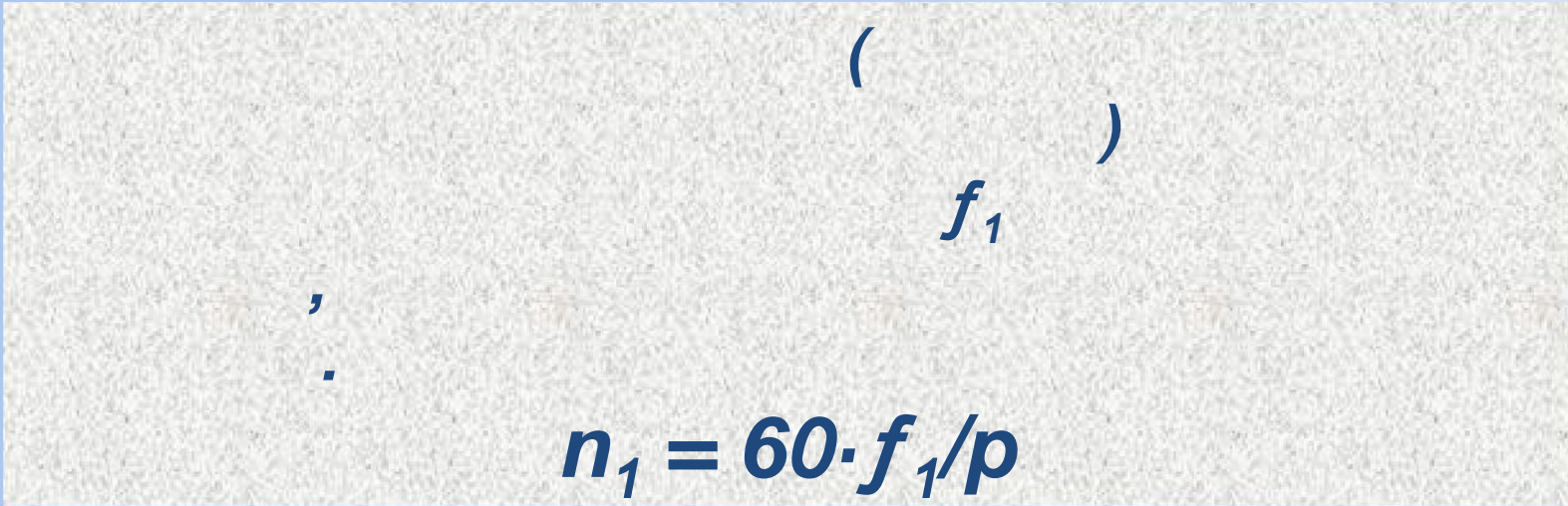
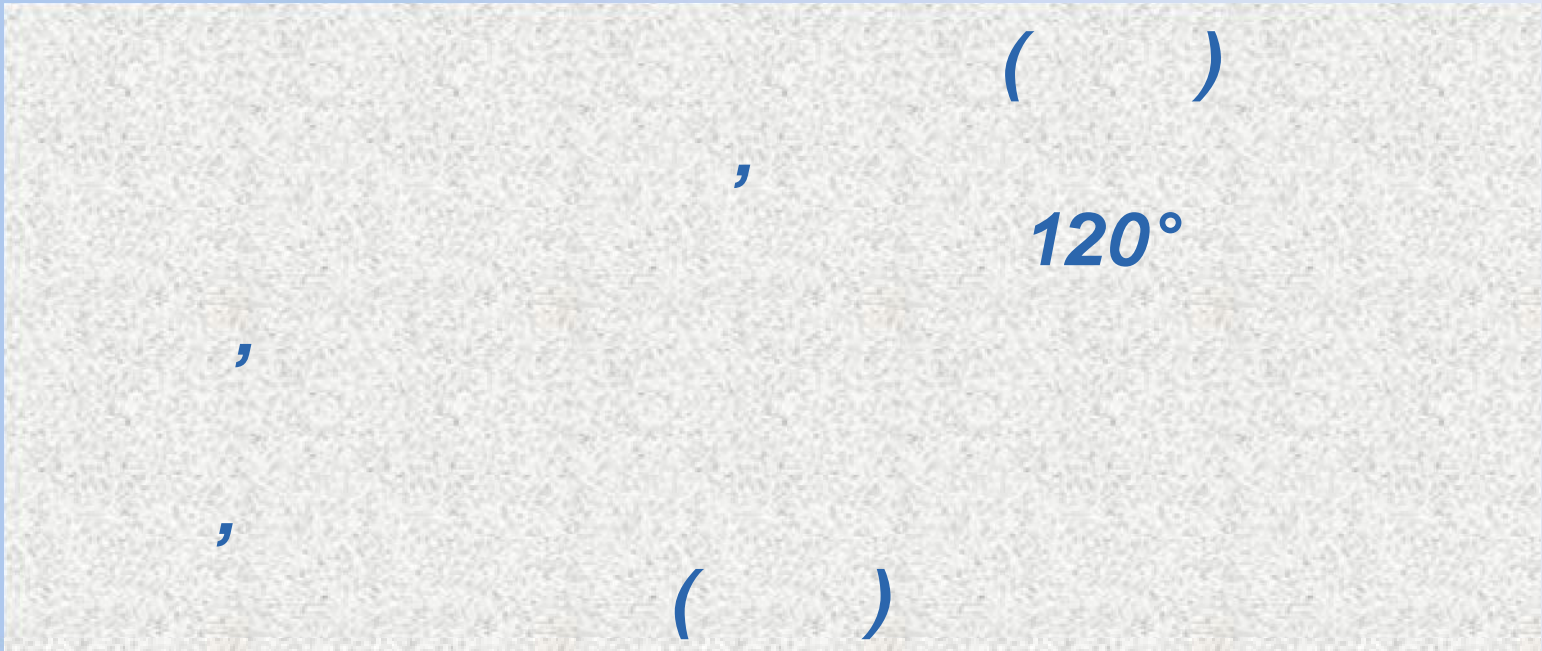

(= 1, 2, 3, 4 . .), $f_1 = 50$

3000;

1500;

1000;

750 /

:

. .

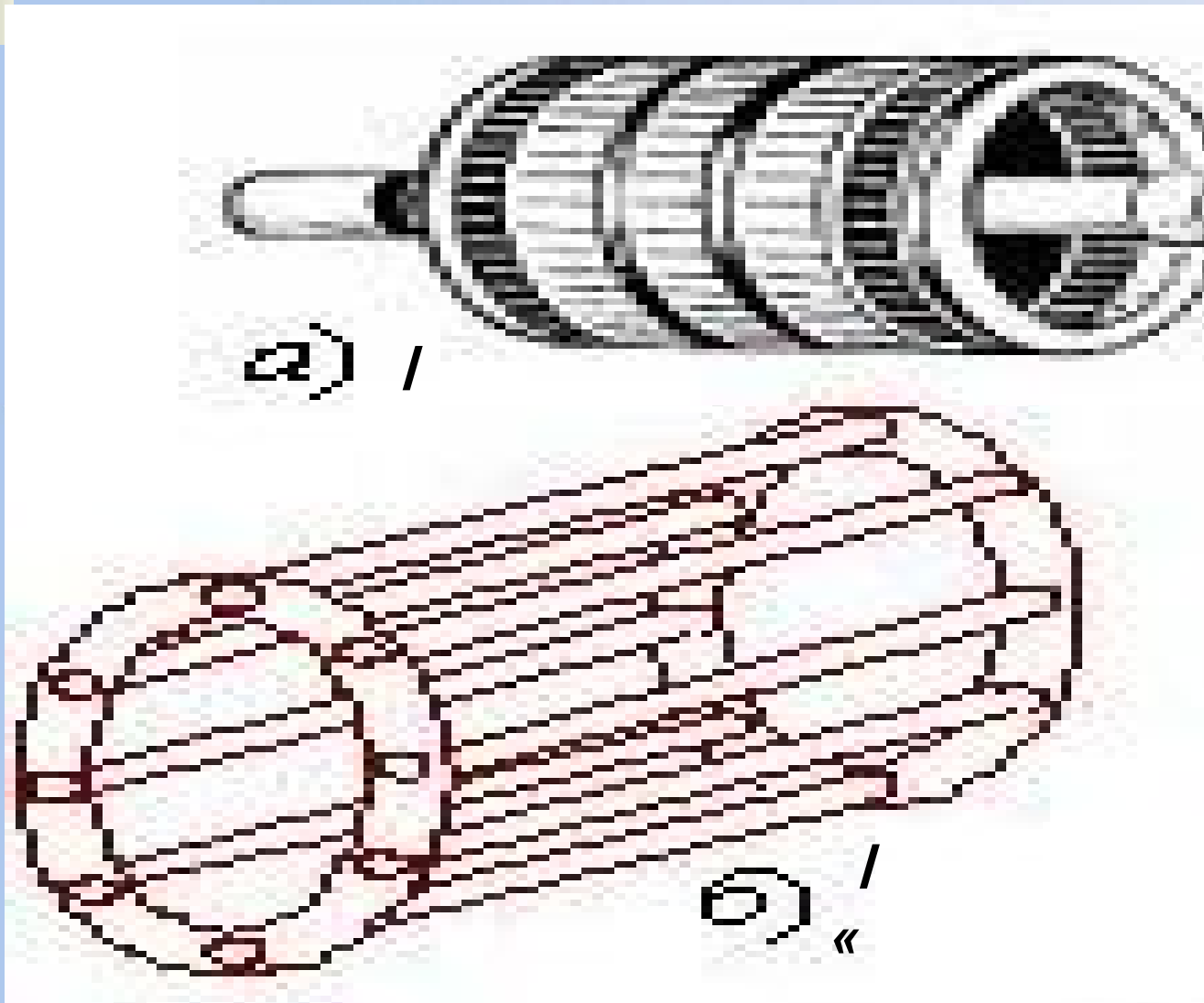
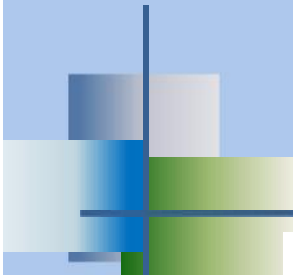

»

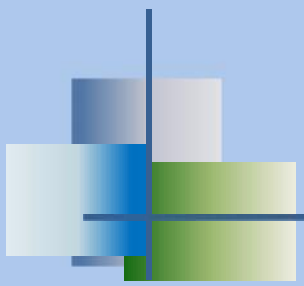

- 1 ;
- 2 ;
- 3 ;
- 5 ;
- 4 .

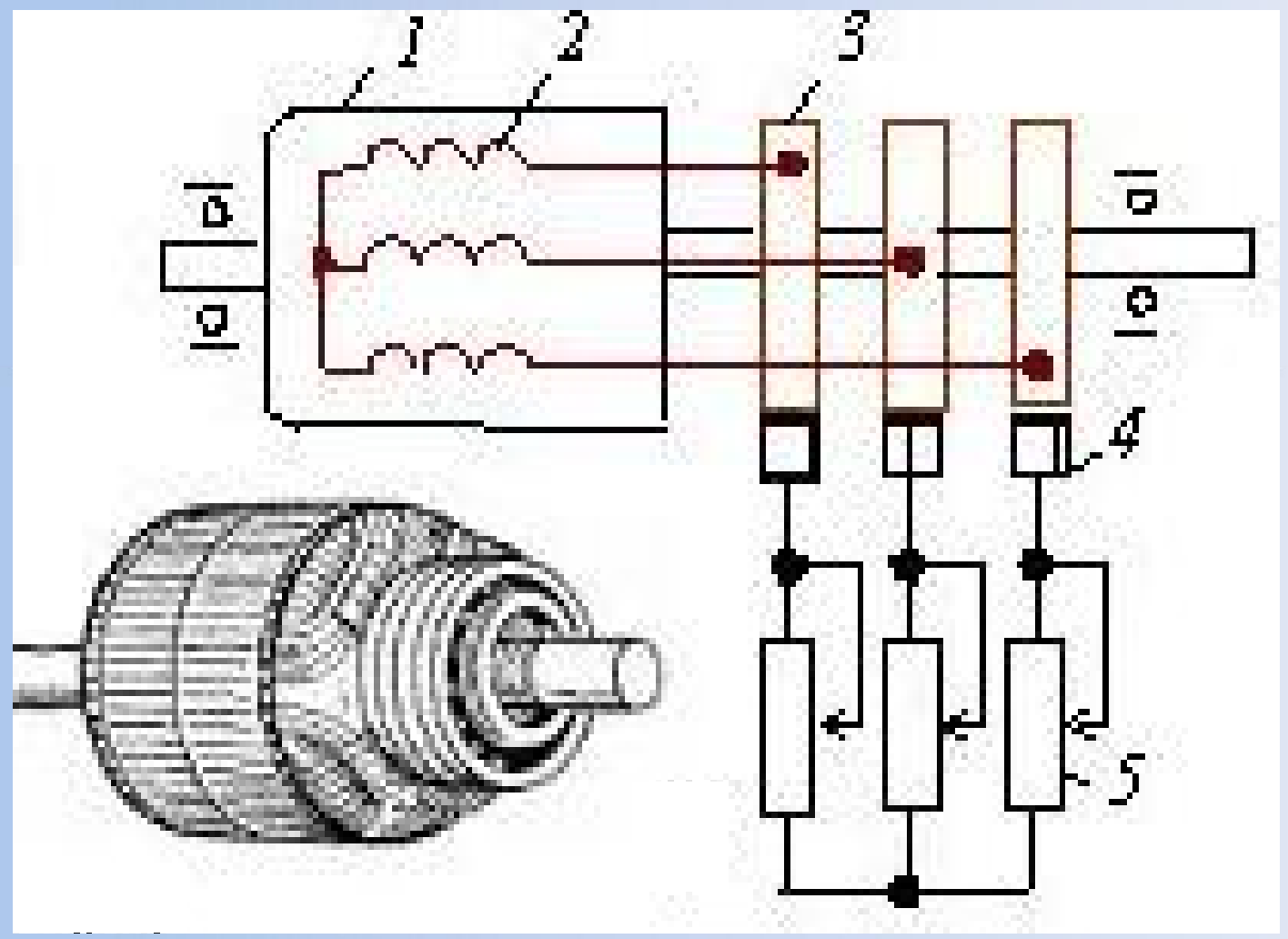

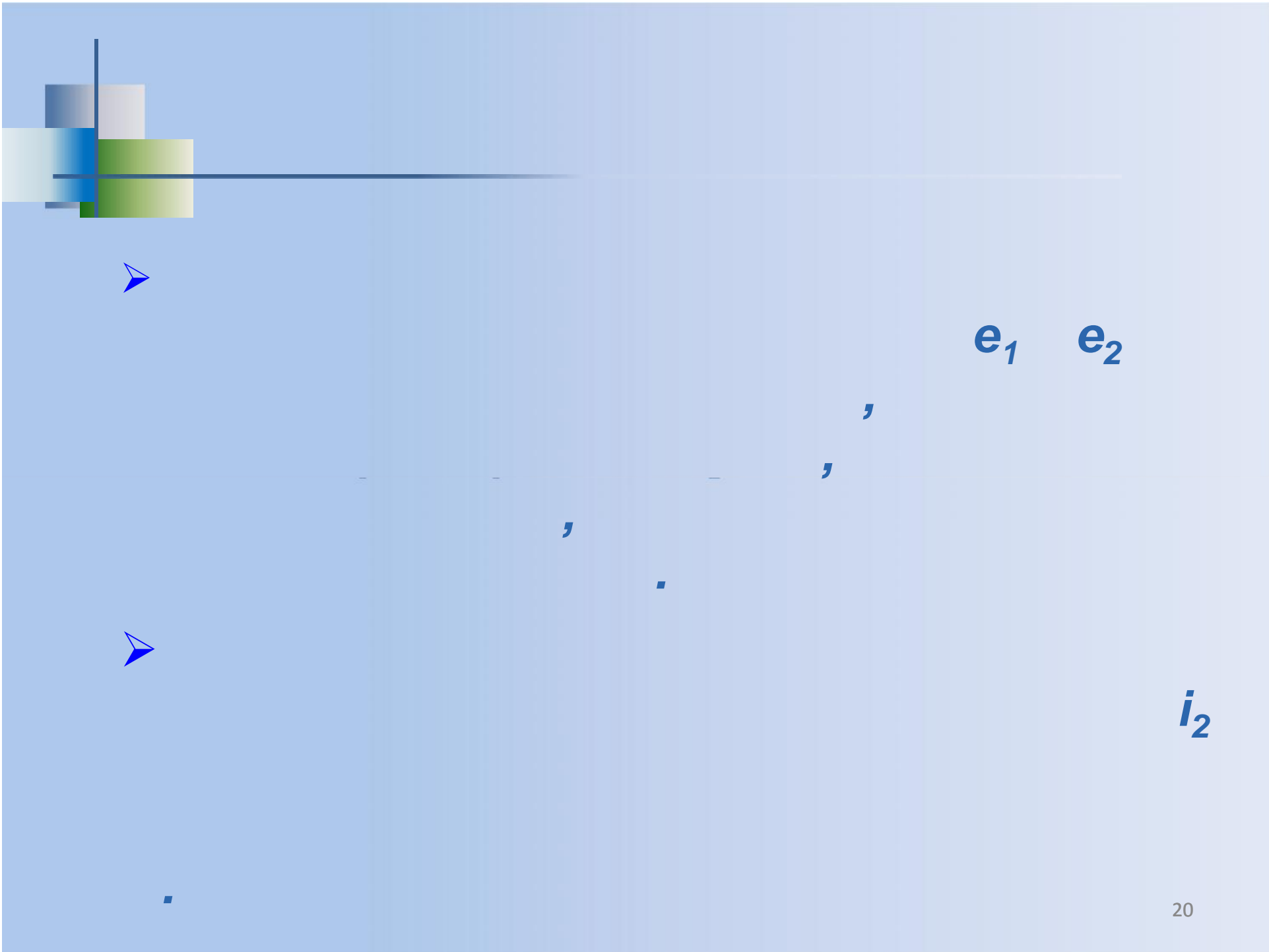

e_1 e_2

i_2

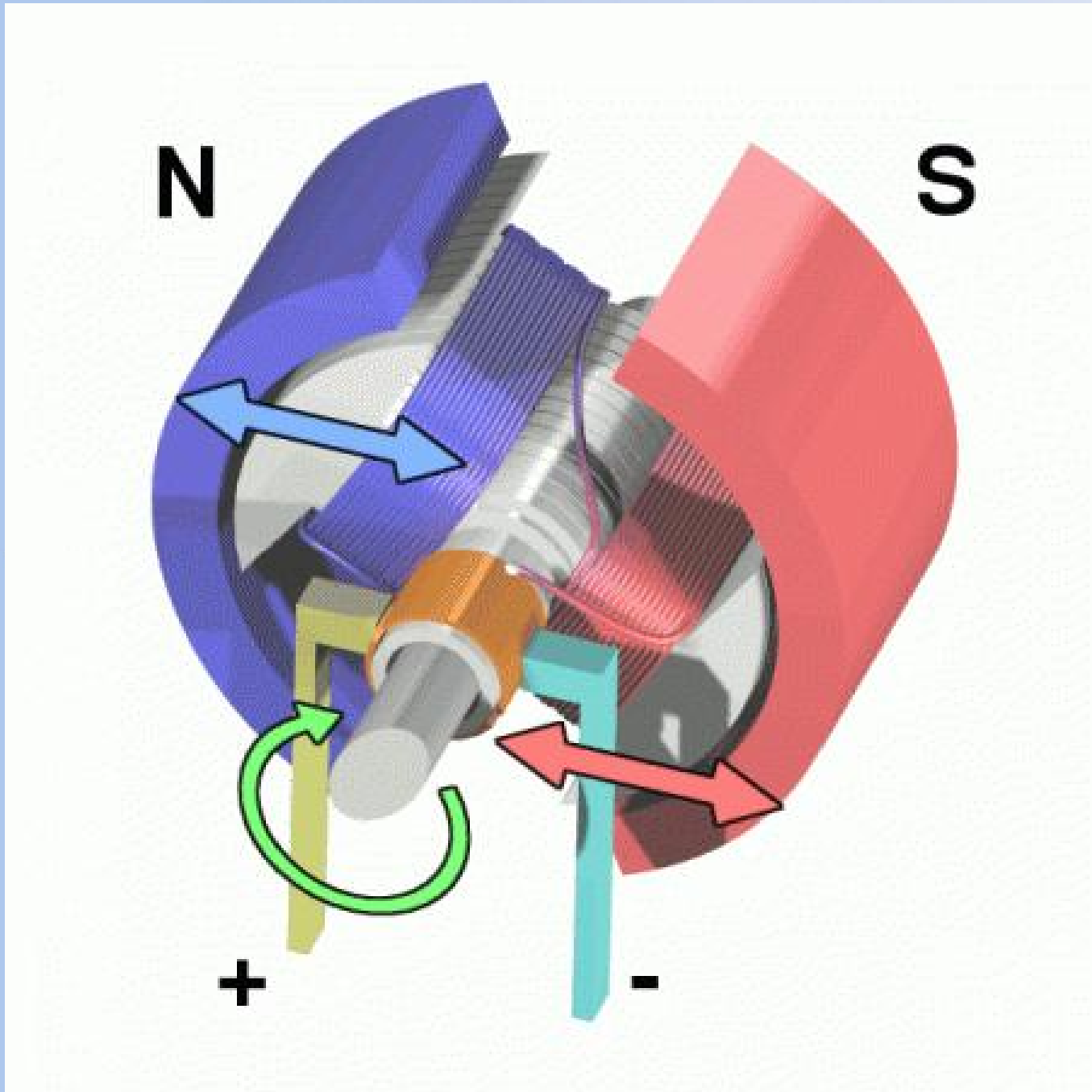

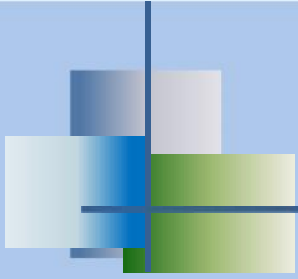

$$M = F \cdot d / 2,$$

$$F = N \cdot B \cdot L \cdot I -$$

(),

B - , ;
 L - ,

N - , ;
 I - , ;
 d - , .



n_2



$n_2 = n_1,$

$n_1.$

,

$e_2,$

i_2

.

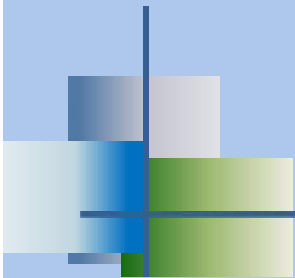

,

$n_2 < n_1,$

.

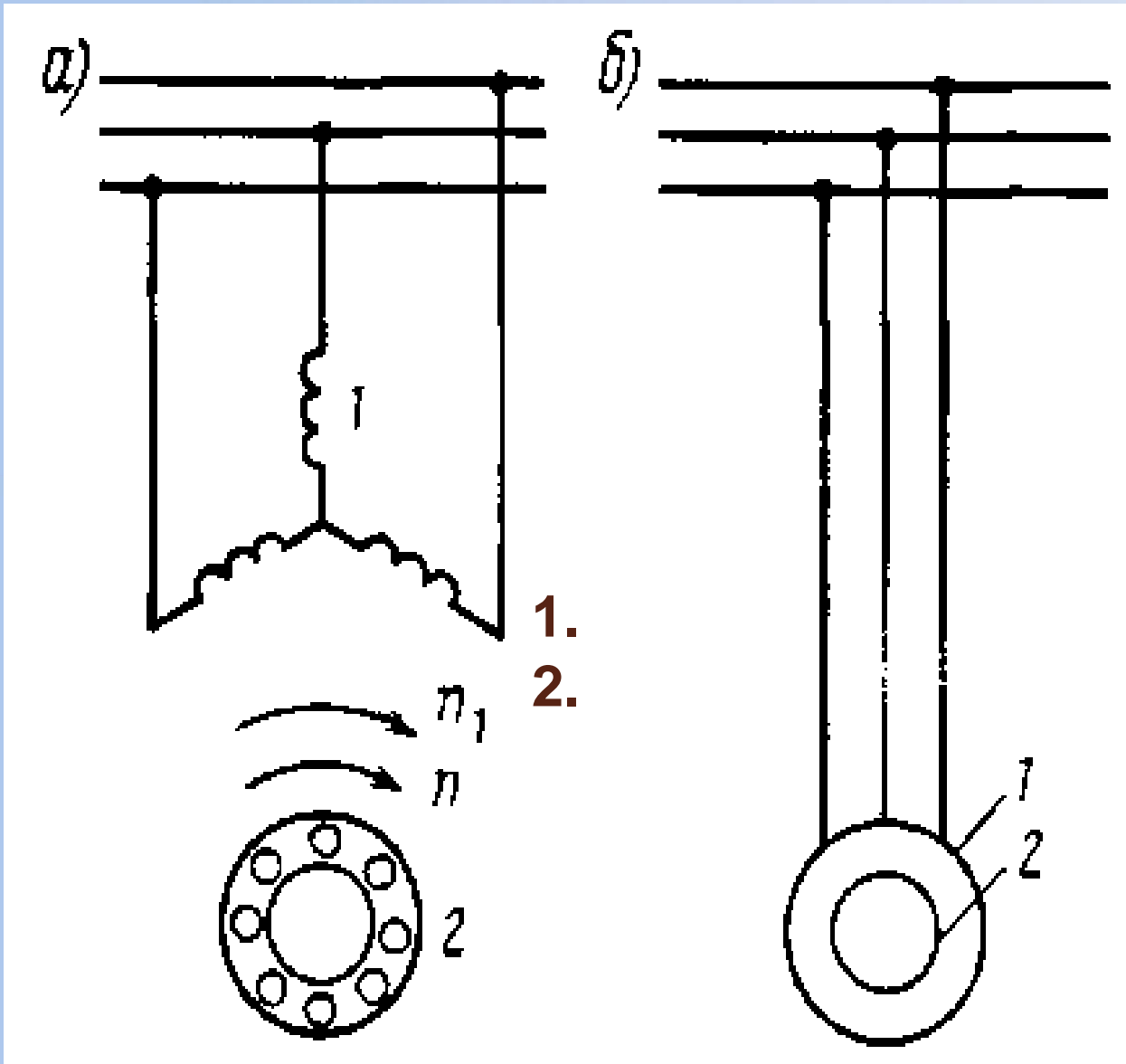

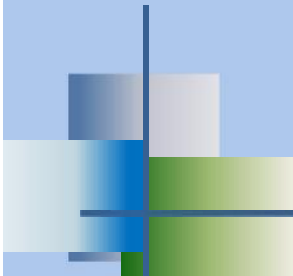

n_2

n_1

$S:$

$$S = \frac{\mu_1 - \mu_2}{\mu_1}$$

$$S\% = \frac{\mu_1 - \mu_2}{\mu_1} 100$$

1 S 0:



$$n_2 = 0, S = 1;$$



$$S = 0,001...0,005;$$



$$S = 0,03...0,07.$$

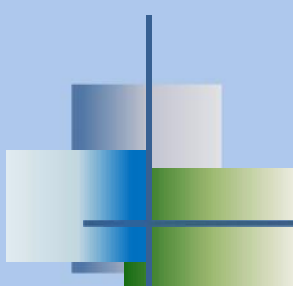

1

2

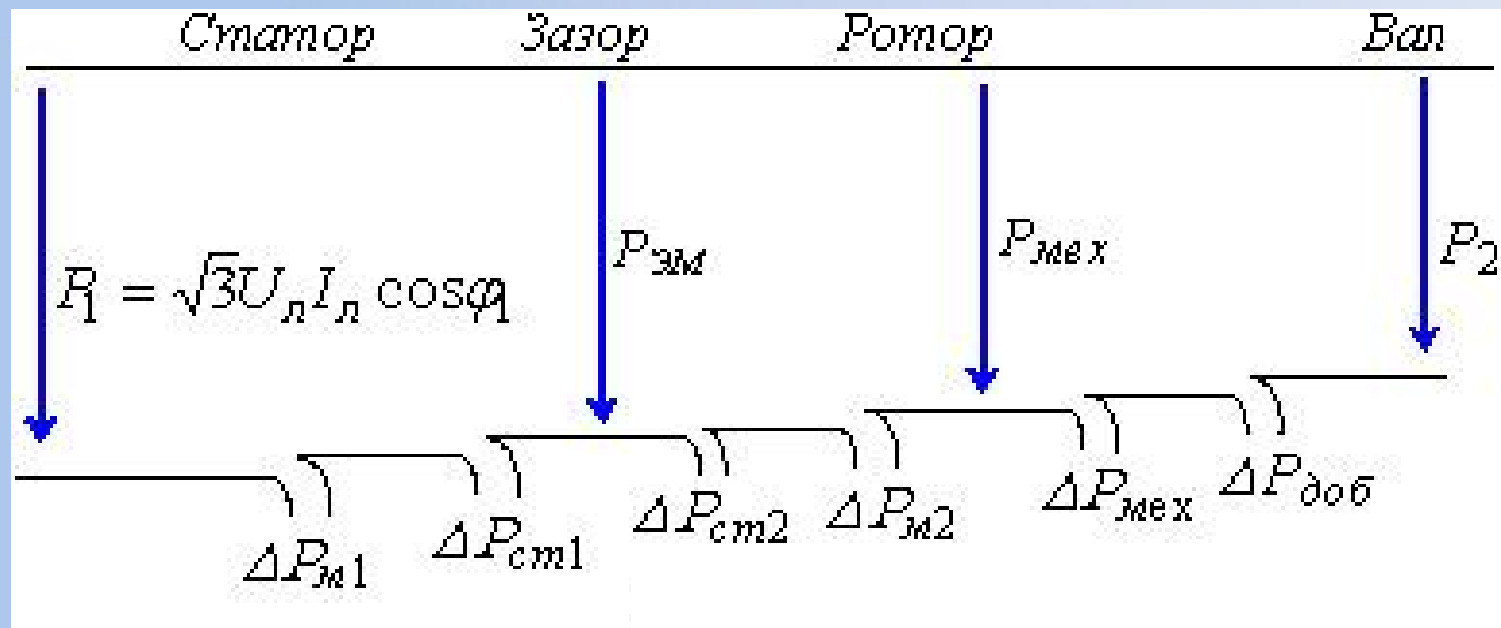

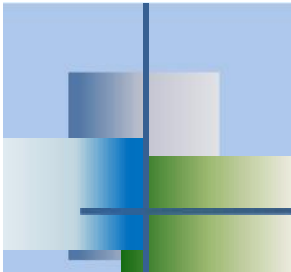

1

:

✓

✓

✓

1

(

)

1

(

),

:

=

1⁻

1⁻

1

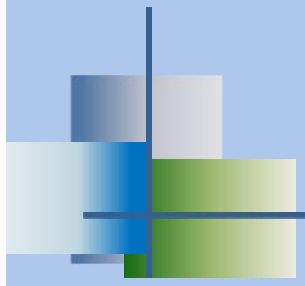

P

:



2 (;
2 ;

P

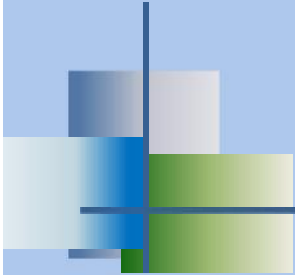

$$n_2 = f(M).$$



M, n_2
.

,

.

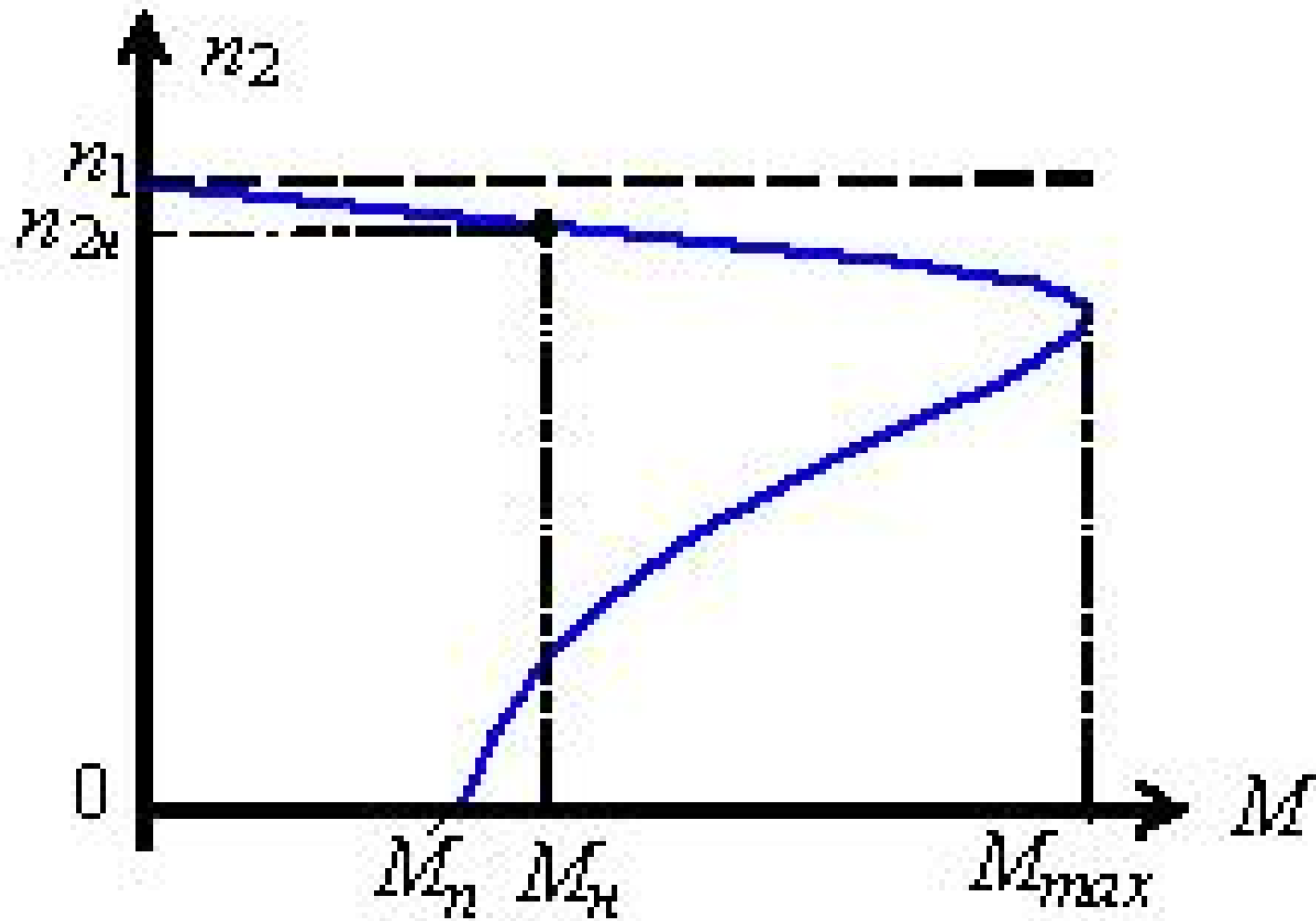

$$\begin{aligned} & \max_{n_2 \in \{0, 8 \dots 0, 9\}} n_1, \\ & \quad n_2 = 0 \\ & = \max_{n_1 \in \{0, 3 \dots 0, 7\}} \end{aligned}$$

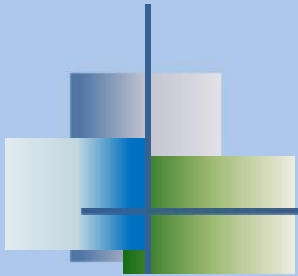

:



_____ ;



_____ ;



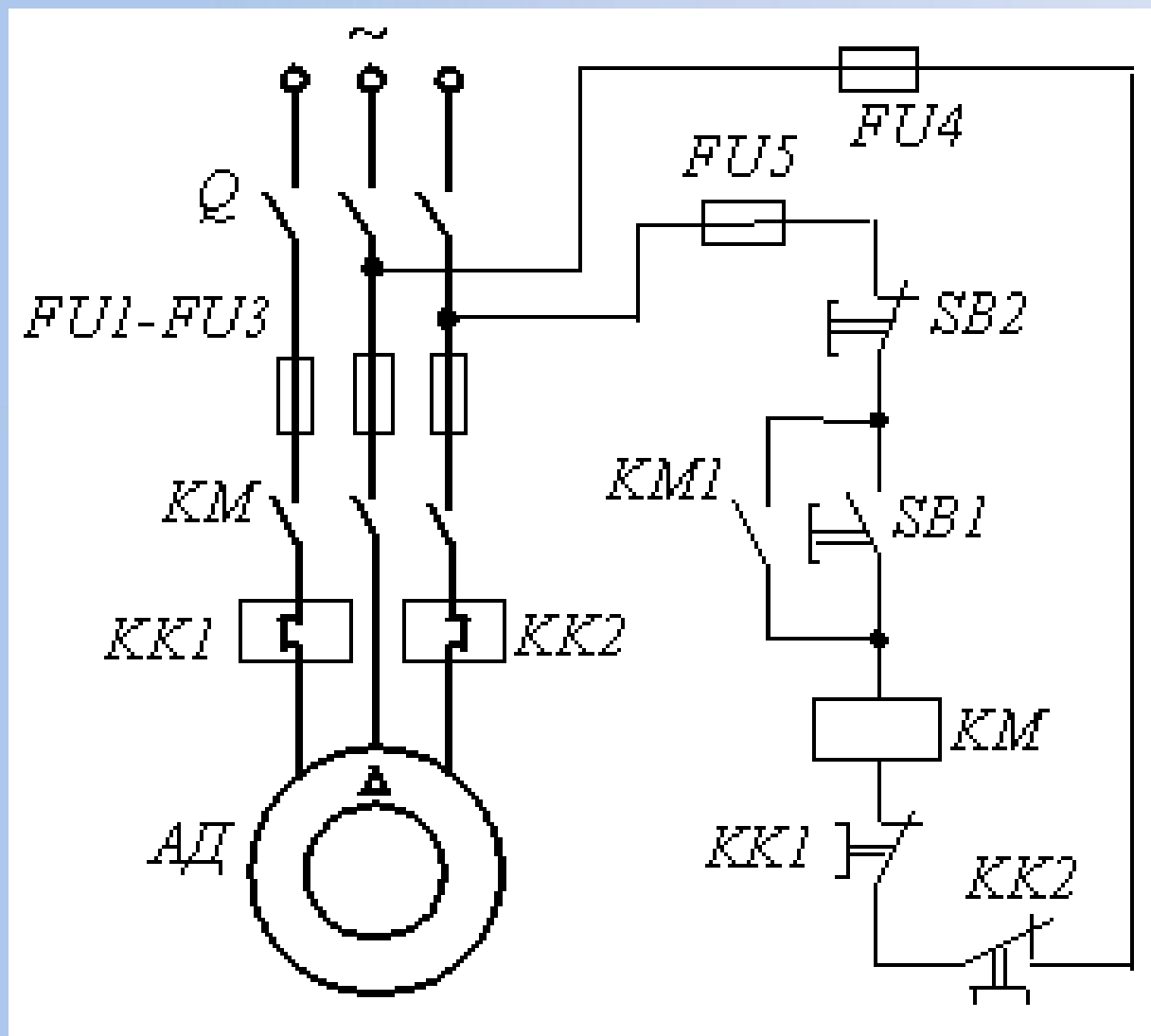



(;)



Y;

()

.



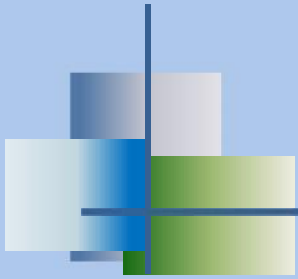

R.



3...6

,

,

.

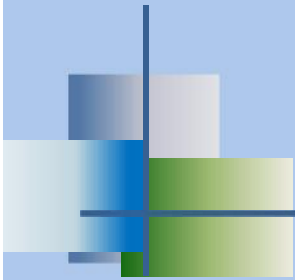

S , n_2 ,

1. f_1 ;
2. () .

(

)

,

,

,

